

ZAWIAS OKIENNY 15/40/9 2XM8/34 Z BOLCEM USTALAJĄCYM

NR PRODUKTU: 9602

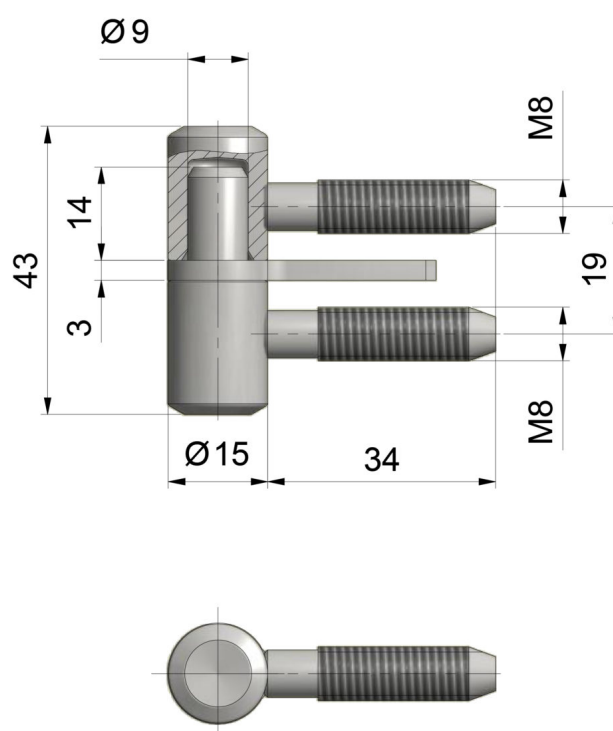

NOŚNOŚĆ	15 KG
ŚREDNICA	15 MM
ŚREDNICA CZOPA	9 MM
MATERIAŁ	STAL
ZASTOSOWANIE	DREWNO
TYP OKNA	PRZYLGOWE

RAMEL sp. z o.o. sp.k.
26-600 Radom, ul. Kalińska 6/6a
tel./fax: 48 384 49 00, 48 366 23 36
www.ramel.pl

